

**Specificare il lato attacchi idraulici batteria**  
**Specify the water coil connections side**

- DX = Destra - Right (STANDARD)
- SX = Sinistra - Left

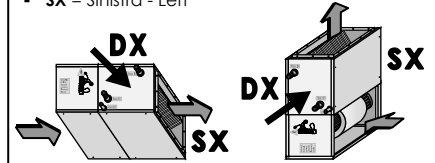

In caso di dubbi interpretativi, si ricorda che le versioni 1...36 riportate a lato sono tutte rappresentate con attacchi destri (DX).  
In case of interpretation doubts, please note that versions 1...36 shown at the side are all represented with right side connections (DX).

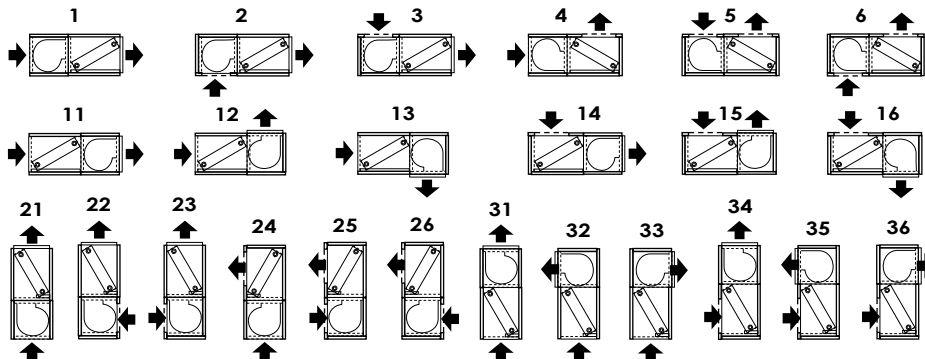

<b>D</b>	Zincato - Incasso Galvanized - Concealed
<b>F</b>	Zincato - A vista Galvanized - With cabinet
<b>H</b>	Preverniciato - A vista Pre-painted - With cabinet
<b>K</b>	Doppio pannello - A vista Double skin panel - With cabinet

## 3R

1 Batteria (unità 2-Tubi)  
1 Coil (2-Pipe unit)

In fase di ordine specificare sempre il Modello completo = Serie + Taglia + Batteria + Cassa portante + Versione + Lato attacchi idraulici. Esempio:  
When ordering, always specify complete Model: Series + Size + Coil + Main casing + Version + Water connections side. Example:

UTMT

1

/

3R

-

H

1

-

DX

➔

UTMTA1/3R-H1-DX

Serie AC-Trifase AC-Threephase Series UTMT (A/B/C) (\*)    Taglia Size 1...16    Batteria Coil 2R, 3R, ...    Cassa portante Main casing D, F, H, K    Versione Version 1...    Attacchi Connections DX, SX

Risultato = Sigla Identificativa per l'ordinazione  
Result = Order Identification code

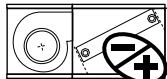

(\*) Disponibili 3 diverse Motorizzazioni:  
• A ➔ UTMTA (Bassa prevalenza)  
• B ➔ UTMTB (Media prevalenza)  
• C ➔ UTMTC (Alta prevalenza)

(\*) Available 3 different Motorizations:  
• A ➔ UTMTA (Low static pressure)  
• B ➔ UTMTB (Medium static pressure)  
• C ➔ UTMTC (High static pressure)

Taglia - Size		UTMT	UTMT 1 3R	UTMT 2 3R	UTMT 3 3R	UTMT 4 3R	UTMT 5 3R	UTMT 6 3R	UTMT 12 3R	UTMT 13 3R	UTMT 14 3R	UTMT 15 4R	UTMT 16 4R	
Pot. Figor. totale - Total cooling cap. (1) kW			7,3	11,7	14,6	17,0	22,2	29,8	24,1	30,1	34,0	58,1	70,1	
Potenza Termica - Heating capacity (2) kW			17,2	28,3	34,9	40,7	52,9	69,9	58,8	71,2	80,9	125,7	157,2	
Portata aria Nom. - Nominal Air flow (3) m³/h			1.500	2.500	3.000	3.500	5.000	6.000	5.000	6.000	7.000	10.000	12.000	
<b>D</b>	<b>INCASSO - ZINCATA CONCEALED - GALVANIZED</b>		Versione in Semplice pannello, autoportante, in lamiera zincata + isolamento termico-acustico interno Self-supporting single skin panel version, made of galvanized steel + internal thermal-acoustic insulation											
		UTMTA	Cod.P	190130004	190230004	190330004	190430004	190530004	190630004	191230004	191330004	191430004	191540004	191640004
		UTMTB	Cod.P	190130005	190230005	190330005	190430005	190530005	190630005	191230005	191330005	191430005	191540005	191640005
		UTMTC	Cod.P	190130006	190230006	190330006	190430006	190530006	190630006	191230006	191330006	191430006	191540006	191640006
<b>F</b>	<b>A VISTA - ZINCATA WITH CABINET - GALVANIZED</b>		Versione in Semplice pannello, autoportante, in lamiera zincata + isolamento termico-acustico interno Self-supporting single skin panel version, made of galvanized steel + internal thermal-acoustic insulation											
		UTMTA	Cod.P	190130014	190230014	190330014	190430014	190530014	190630014	191230014	191330014	191430014	191540014	191640014
		UTMTB	Cod.P	190130015	190230015	190330015	190430015	190530015	190630015	191230015	191330015	191430015	191540015	191640015
		UTMTC	Cod.P	190130016	190230016	190330016	190430016	190530016	190630016	191230016	191330016	191430016	191540016	191640016
<b>H</b>	<b>A VISTA - PREVERNICIATA WITH CABINET - PRE-PAINTED</b>		Versione in Semplice pannello, autoportante, in lamiera preverniciata bianca RAL 9002 + isolamento termico-acustico interno Self-supporting single skin panel version, made of white RAL 9002 pre-painted steel + internal thermal-acoustic insulation											
		UTMTA	Cod.P	190130024	190230024	190330024	190430024	190530024	190630024	191230024	191330024	191430024	191540024	191640024
		UTMTB	Cod.P	190130025	190230025	190330025	190430025	190530025	190630025	191230025	191330025	191430025	191540025	191640025
		UTMTC	Cod.P	190130026	190230026	190330026	190430026	190530026	190630026	191230026	191330026	191430026	191540026	191640026
<b>K</b>	<b>A VISTA - DOPPIO PANNELLO WITH CABINET - DOUBLE PANEL</b>		Versione in Doppio pannello, autoportante, in Lamiera zincata / Fibra vetro / Lamiera preverniciata bianca RAL 9002 Self-supporting double skin panel version, made of Galvanized steel / Glass fibre / White RAL 9002 pre-painted steel											
		UTMTA	Cod.P	190130034	190230034	190330034	190430034	190530034	190630034	191230034	191330034	191430034	191540034	191640034
		UTMTB	Cod.P	190130035	190230035	190330035	190430035	190530035	190630035	191230035	191330035	191430035	191540035	191640035
		UTMTC	Cod.P	190130036	190230036	190330036	190430036	190530036	190630036	191230036	191330036	191430036	191540036	191640036