

F

ENFRIAMIENTO EVAPORATIVO



MET MANN
Creando Clima desde 1959



www.metmann.com
Tel. +34 93 851 15 99



FRESC MANN PREMIUM

ECOLOGICAL EVAPORATIVE COOLERS. 4,200 TO 12,000 M³/H

The portable FRESC MANN and BRIS MANN evaporative coolers are ideal solutions for reducing temperatures in work rooms, in areas where heat collects or in other average-sized spaces, wherever an economical, effective and energy-saving system is needed.

These models can be equipped with a fixed air flow level or with a control panel that allows full adjustment of the flow as necessary.

Some of the manufacturing details include:

- Front air discharge with double-deflection impulsion grill (FRESC MANN model) or top air diffuser with eight discharge ports (BRIS MANN model).
- Basic units with integrated 1-speed electrical panel or electrical panel with frequency converter that allows flow regulation.
- Fan with integrated motor or with clutch system.
- Fan with bonded RAL 7035 gray anti-corrosion treatment (FR-09 / FR-12).
- Anti-corrosion bearings with tank cover included (FR-09 / FR-12).
- Rigid structure made from high-thickness polyamide with interior attachments.
- AISI-304 stainless steel corner posts.
- High-performance cooling panels with protective grills in RAL 7035 gray.
- Nylon wheels for ease of transport.
- 25m hose included with quick-connect system.
- Manual emptying system with corrosion-resistant valve.
- Factory-installed hydraulic and electrical connections.

10-year guarantee for polyamide base and top, 2-year guarantee for other components.

The integrated design and manufacturing carried out by MET MANN has taken into consideration the need for high performance, ease of installation and guaranteed efficiency and durability over time.

10-year guarantee for polyamide base and top, 2-year guarantee for other components.

The integrated design and manufacturing carried out by MET MANN has taken into consideration the need for high performance, ease of installation and guaranteed efficiency and durability over time.

Designed and built by
MET MANN

10-year guarantee
for the polyamide structure
1-year guarantee
for the other components

Rental with option
to buy for equipment

WHY MET MANN?

- 10-YEAR GUARANTEE FOR ALL CONSTRUCTED ELEMENTS.
- WE ARE MANUFACTURERS AND CAN ADAPT PRODUCTS TO YOUR NEEDS.
- FULLY PERSONALIZED TECHNICAL AND COMMERCIAL CONSULTATION.
- GUARANTEED SUPPLY OF REPLACEMENT PARTS FOR 10 YEARS



DOUBLE-DEFLECTION GRILLS ON THE FRESC MANN MODEL.



QUICK-OPENING APERTURES WITH HALF-TURN KNOB.



PANEL DE CONTROL FRONTAL DE FRONT CONTROL PANEL, 1-SPEED OR VARIABLE FLOW.



8-DIRECTION AIR DIFFUSER WITH SINGLE-DEFLECTION GRILLS ON THE BRIS MANN MODEL.



QUICK-CONNECT HOSE FOR CONNECTION TO WATER SOURCE.



NYLON WHEELS FOR MOBILITY.

FRESC MANN FRONT AIR DISCHARGE



CODE	MODEL	AIR FLOW m³/h	REGULATION OF FLOW	COOLING PANEL THICKNESS mm	COOLING PANEL EFFICIENCY %	FAN POWER kW	PUMP POWER W	VOLTAGE FAN/PUMP
15010073147	FR-07 Variable	4.200	VARIABLE	50	65	0,75	38	A/A
15010092145	FR-09 1 speed	9.000	1 SPEED	50	66	0,75	38	B/A
15010092144	FR-09 Variable	9.000	VARIABLE	50	66	0,75	38	B/A
15010122145	FR-12 1 speed	12.000	1 SPEED	75	78	1,10	38	B/A
15010122144	FR- 12 Variable	12.000	VARIABLE	75	78	1,10	38	B/A
15010152145	FR-15 1 speed	15000	1 SPEED	100	87	2,2	38	B/A
15010152144	FR-15 Variable	15000	VARIABLE	100	87	2,2	38	B/A

BRIS MANN PERIMETER AIR DISCHARGE WITH EIGHT AIR VENTS



CODE	MODEL	AIR FLOW m³/h	REGULATION OF FLOW	COOLING PANEL THICKNESS mm	COOLING PANEL EFFICIENCY %	FAN POWER kW	PUMP POWER W	VOLTAGE FAN/PUMP
1501FA073	FA-07 Variable	4.200	VARIABLE	50	65	0,75	38	A/A

VOLTAGE: A-230V/I/50HZ B-400V/III/50HZ

DIMENSIONS

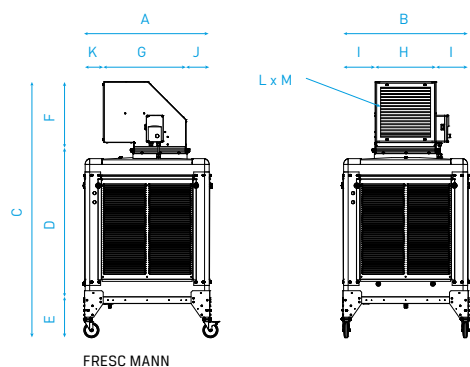

FRESC MANN

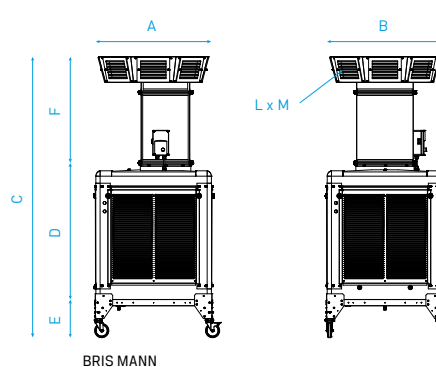

BRIS MANN

DIMENSIONS mm

MODEL	A	B	C	D	E	F	G	H	I	J	K	L x M	EMPTY WGT.	WGT. W/WATER
FR-07	825	825	1700	980	270	450	550	405	210	155	120	350X350	110	120
FR-09	1135	1135	2110	1140	270	700	650	655	240	145	340	600X600	190	210
FR-12	1135	1135	2110	1140	270	700	650	655	240	145	340	600X600	200	220
FR-15	1135	1135	2110	1140	270	700	650	655	240	145	340	600X600	210	230

DIMENSIONS mm

MODEL	A	B	C	D	E	F	L x M	EMPTY WGT.	WGT. W/WATER
FA-07	825	825	1995	970	270	755	200X150 (8U.)	115	125

IMPULSION TEMPERATURES

Evaporative cooler FR-07

HUMIDITY	EXTERIOR TEMPERATURE		34	36	38	40	42	44
	30	32						
20%	18	20,2	21,6	23	24,4	25,8	27,2	28,6
25%	20,1	21,6	23,1	24,5	26,1	27,5	29,1	30,5
30%	21,5	22	24,5	26,1	27,6	29,2	30,8	32,3
40%	23,8	25,4	27,1	28,8	30,5	32,2	34	35,6
50%	25,9	27,7	29,5	31,4	33,1	35	36,9	38,7

Evaporative cooler FR-09

HUMIDITY	EXTERIOR TEMPERATURE		34	36	38	40	42	44
	30	32						
20%	19,2	20,5	22	23,3	24,8	26,1	27,5	29
25%	20,4	22	23,4	24,9	26,4	27,9	29,4	30,8
30%	21,8	23,3	24,9	26,4	28	29,6	31,2	32,8
40%	24,1	25,8	27,4	29,2	30,8	32,6	34,4	36,1
50%	26,2	28,1	29,9	31,7	33,5	35,4	37,2	39,1

Evaporative cooler FR-12

HUMIDITY	EXTERIOR TEMPERATURE		34	36	38	40	42	44
	30	32						
20%	17,6	18,9	20,3	21,6	22,9	24,2	25,6	27
25%	18,8	20,3	21,7	23,1	24,5	25,9	27,4	28,8
30%	20,1	21,6	23,1	24,5	26,1	27,5	29,1	30,6
40%	22,3	23,9	25,5	27,2	28,8	30,5	32,2	33,7
50%	24,3	26,1	27,9	29,7	31,3	33,1	34,9	36,7

Evaporative cooler FA-07

HUMIDITY	EXTERIOR TEMPERATURE		34	36	38	40	42	44
	30	32						
20%	18	20,2	21,6	23	24,4	25,8	27,2	28,6
25%	20,1	21,6	23,1	24,5	26,1	27,5	29,1	30,5
30%	21,5	22	24,5	26,1	27,6	29,2	30,8	32,3
40%	23,8	25,4	27,1	28,8	30,5	32,2	34	35,6
50%	25,9	27,7	29,5	31,4	33,1	35	36,9	38,7



MET MANN

Creando Clima desde 1959

Metalúrgica Manlleuense S.A.

Fontcuberta, 32-36
Apartado de correos 23
08560 Manlleu (Barcelona)
SPAIN

Contact for customers

T +34 93 851 15 99
F +34 93 851 16 45
www.metmann.com
metmann@metmann.com

